

## Spray characterization of nozzle for fire extinguisher

Varun. K. R,<sup>1</sup> Rajashekhar. C. R,<sup>2</sup> Bhaskar Dixit<sup>3</sup>

<sup>1,2</sup>Student, Department of Mechanical Engineering, Sri Siddhartha University, India

<sup>3</sup>Professor, Department of Centre for Disaster Mitigation, Jain University, India

**Abstract:** The development of water mist fire suppression technology has made substantial progress over the last decade. Water mist based techniques are becoming popular but the fire extinguishment products call for high initial investment. There exists a need to develop cost effective water mist generation techniques appropriate for fire suppression.

A standard portable water-CO<sub>2</sub> fire extinguisher nozzle is selected for study with an application density of 1.0 l/min/m<sup>2</sup>. A multi-jet nozzle with opposed jet configuration is developed to get improved spray characteristics. Droplet Sauter Mean Diameters (SMD) were empirically calculated using correlations available in the literature.

The spray developed has resulted in droplets with SMD in the range of 0.3 – 0.4 mm as calculated from correlations and confirmed using experimental measurements.

**Keywords:** atomization, fire suppression, portable water extinguishers, spray nozzles, water spray

### I. Introduction

Water is the most cost effective reagent for fire extinguishment. Water in the form of jets/sprays is used for fire suppression. Water dispensation at an optimal rate is essential to improve effectiveness of utilization and also protect the fire affected regions from the ill effects of water inundation in the post fire scenario. Several studies exist in the literature aimed at improving the utilization efficiency of water during fire suppression [1, 5, 6]. Breaking up water jets into finer particles improves surface area available for heat absorption but smaller particle mass reduces penetration of water into fire. Mist based extinguishers are available in the market which claim lower water consumption but they are prohibitively expensive and therefore their availability for use is restricted. Even to this day, the flow rates employed in Class-A fire extinguishers available in the market utilize large application densities (>1 l/min/m<sup>2</sup>) to ensure effectiveness in extinguishment. Therefore, there exists a scope for improvement in water utilization effectiveness of fire extinguishers.

Standard issue portable water CO<sub>2</sub> fire extinguisher of 9 l volume is selected for the present study. Water jet nozzle is replaced with a multi-jet opposed configuration.

### II. Literature survey

Grant et al [1] have reviewed class a fire suppression using water sprays. State-of-the-art on quantitative characterization of water sprays, spray patterns and practical methods for measuring drop size distribution with equations and correlations are discussed. Several nozzle configurations appropriate for fire extinguishment are described. Issues associated with quenching crib fires are also discussed.

Liu and Kim [2] have discussed extinguishing mechanisms involved in the water mist systems. Factors which affect the water mist performance are highlighted.

Meenakshi and Rajora [4] have tested performance of water mist generated with a mist nozzle of diameter 0.5 mm. Ultra fine mist of size 17 microns is generated and tested on an enclosed fire.

Adiga, et al. [3] have discussed suppression effectiveness of ultra fine mist, less than 10 microns in size by simulating the fire using fluent, Computational Fluid Dynamics (CFD) software.

Sridhara and Raghunandan [6] have discussed flow visualization techniques for evaluating the spray characteristics using different lighting techniques.

Roberts [7] has discussed the measurement of droplet characteristics. This paper discusses the three stages to obtain data on droplet sizes. This paper employs still photography and also high speed video image capturing techniques for measurement.

Estes and Mudawar [8] have worked on empirical correlations for water sprays. 3W argon ion laser based Phase Doppler Particle Analyzer (PDPA) is used for spray characterization. The mean diameter used to describe a spray depends on its intended use: 'Sauter Mean Diameter' (SMD) of the droplets is normally employed. It defines a droplet which has the mean surface area and mean volume for the whole spray. It is equally relevant to the behavior of fuel in combustion problems and water sprays used in fire fighting.

$$D_{ab} = \left( \frac{\sum N_i D_i^a}{\sum N_i D_i^b} \right)^{1/(a-b)} \quad (1)$$

Sauter Mean Diameter,  $d_{32}$ , uses  $a=3$  and  $b=2$  in equation 1 to calculate mean diameter. The paper recommends correlation given in equation 2.

$$\frac{d_{32}}{d_0} = [We_{d_0}^{0.5} Re_{d_0}]^{-0.259} \quad (2)$$

Viriato Semibo, Pedro Andrade and Maria da Gra Ca Carvalho [9], have worked on numerical prediction of SMD for sprays. The paper has discussed several correlations used in atomizers. Correlation given in equation 3 is recommended for water sprays of the type used in the current work.

$$SMD = A \left[ \frac{\sigma^{0.5} \mu_L}{\rho_A^{0.5} \Delta P_L} \right]^{0.5} (t \cos\theta)^{0.25} + B \left[ \frac{\sigma \rho_L}{\rho_A \Delta P_L} \right]^{0.25} (t \cos\theta)^{0.75} \quad (3)$$

### III. Studies on spray

#### 1.1. Nozzle design

The nozzle is being fabricated as shown in figure. The concept of the design of the nozzle is to pass the water from one end and while the water coming from the other face is to be get atomized. In this point of view the design is made in such a way that the water is atomized in the out section of nozzle. At the out section of the nozzle which is on the closed side, six holes are drilled at some particular angle.

The nozzle used in the current work is shown in fig1. The nozzle is based on opposed jet configuration where several jets converge to a point and disperse resulting in a spray of water with finer particle size. Six angular holes of 0.7 mm diameter are drilled on a PCD of 7 mm. Hole axis inclination is such that the jets oppose each other at a distance of 15 mm resulting in an effective jet break up. Total orifice area is comparable to standard jet nozzle area of the extinguisher.

Flow rates from the nozzle is evaluated at several pressures and compared with standard nozzle. Figure 2 gives the comparison. The setup used to generate the spray is described in Figure 6.

The various tests are being conducted from the nozzle. The mass flow rate at various pressures is studied and tabulated and a graph is also plotted between pressure verses mass flow rate and compares with the theoretical calculation and at the 6bar pressure and spray characterization is studied.

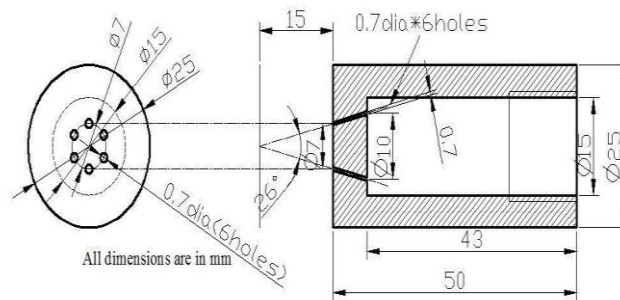

Fig. 1: Engineering drawing of opposed jet nozzle

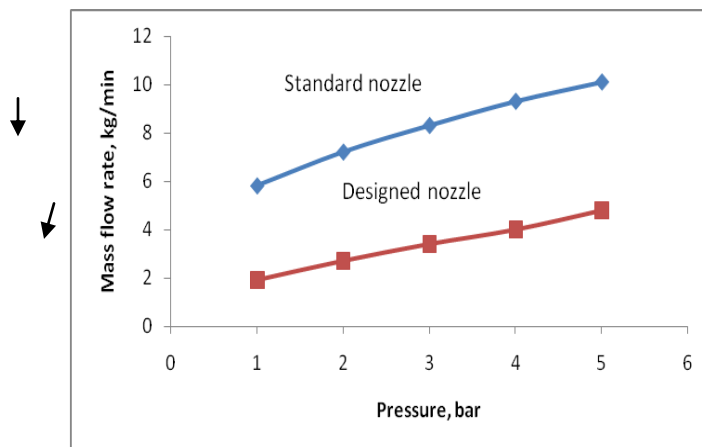

Fig. 2: Effect of pressure on mass flow rates

#### 1.2. Effect of mass flow rate

Fig 3 gives the comparison between the theoretical and experimental mass flow rates for the opposed jet configuration nozzle.

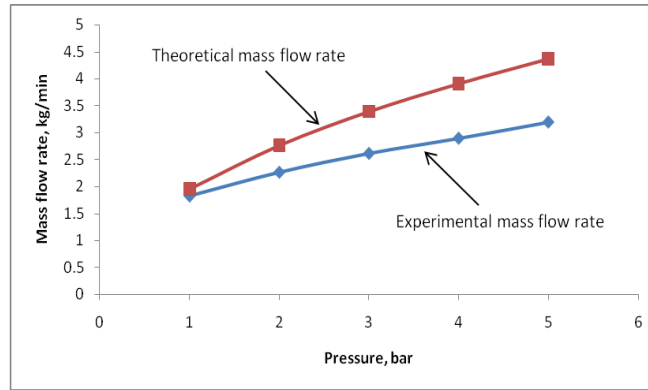

Fig 3: Effect of theoretical and experimental mass flow rate with pressure

Fig 4 shows the schematic representation of the spray, in which the cone angle, jet break up length, throw of the spray and width of the spray is measured at 6 bar pressure from the opposed jet nozzle configuration.

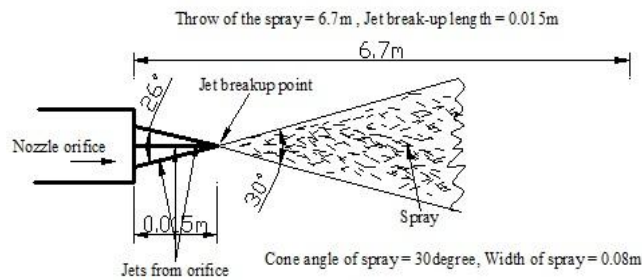

Fig 4: Spray characterization

### 1.3. Sauter Mean Diameter

Sauter mean diameter (SMD,  $d_{32}$  or  $D[3, 2]$ ) is an average of particle size. It was originally developed by German scientist J. Sauter in the late 1920s. It is defined as the diameter of a sphere that has the same volume/surface area ratio as a particle of interest.

The value of  $d_{32}$  using the correlation from the equation (2), at 6bar gauge pressure, was found to be,

$$\frac{d_{32}}{d_0} = [We_{d_0}^{0.5} Re_{d_0}]^{-0.259}$$

$$d_{32} = 0.293\text{mm}$$

The value of the SMD calculated using the correlation from the equation (3), at 6bar gauge pressure was found to be,

$$SMD = A \left[ \frac{\sigma^{0.5} \mu_L}{\rho_A^{0.5} \Delta P_L} \right]^{0.5} (t \cos \theta)^{0.25} + B \left[ \frac{\sigma \rho_L}{\rho_A \Delta P_L} \right]^{0.25} (t \cos \theta)^{0.75}$$

$$SMD = 0.317\text{mm}$$

The result of the calculated SMD obtained from the jet equation (2) and equation (3) are almost similar.

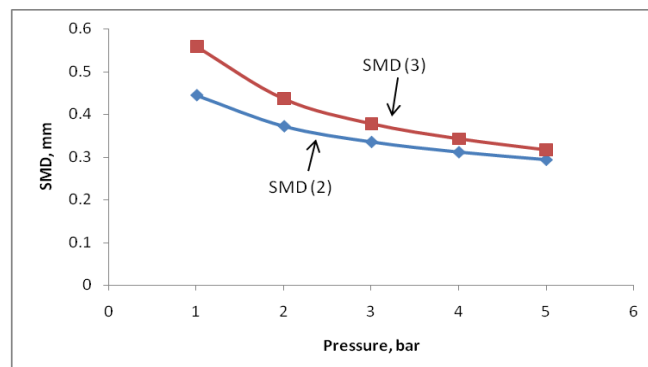

Fig. 5: Effect of Pressure on SMD

Figure 5 shows effect of pressure on predicted SMD from two different correlations. The predicted values from both correlations quantitatively agree with each other. The rate of decrease of SMD is demonstrated to be large at pressures below 3 bar and beyond 3 bar; the decrease in SMD with increase in pressure is small.

#### IV. Experimental set up

The Figure 6 give a schematic description of experimental set up used for testing the sprays. Regulated air supply from a two stage air compressor (300 l/min Free Air Delivered, 200 l reservoir and 12 bar pressure) is employed. Additional reservoir of 150 l capacity is used as buffer. Air from the reservoir is used to pressurize the 9 l capacity portable extinguisher chamber. Water is drawn from the bottom of cylinder and forced through the nozzle due to the pressure above water surface as indicated in Figure 6. The mass flow rate is checked for different pressures in the set up shown in fig 6.

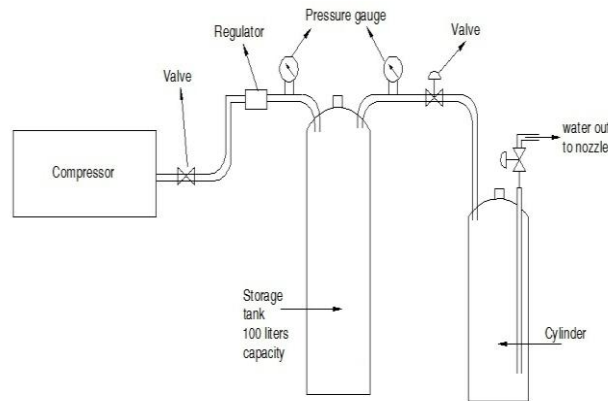

Fig. 6: Opposed jet spray generation system

#### V. Experimentation

The empty cylinder weight is noted before filling the water. The water is filled into the cylinder and closed tightly ensuring no leakage and weight of the cylinder is noted and tabulated. All the connections are made sequentially and ensure no leakage in any point. The compressor is connected to the air tank through the pressure gauge and pressure valve. The air tank is connected to the cylinder to pressurize the water in the cylinder through pressure gauge. The compressor is made to run till it reaches its maximum pressure and automatically stops. The pressure is released and check for any leakage in connecting points. The pressure is released and adjusted to the required pressure using the pressure valve.

Once the pressure is set in the pressure valve then the pressure is released to the cylinder. The empty bucket weight is noted. Initially the pressure is set to 2bar and amount of water collected is noted. The readings are taken for different pressures 2bar to 6bar. There are nearly five to six trials are taken at each pressure. The readings are noted and tabulated for different pressures. The graph is plotted between pressure and mass flow rate.

#### VI. Result and discussion

Experiments were carried out with the opposed jet nozzle. The mass flow rate were checked at different pressures from 1 bar to 6 bar and compared the performance of the opposed jet configuration nozzle with the standard nozzle used in standard water-CO<sub>2</sub> fire extinguisher as shown in fig 2. This shows the utilization of water in opposed jet nozzle is less compared to standard.

Fig 3 shows the comparison of the theoretical and experimental mass flow rate from nozzle. The experimental readings appears to be less compared to the theoretical, this is may be due to the losses while conducting the experiments.

The value of  $d_{32}$ , using the correlation from the equation 2, at 6 bar gauge pressure, is 0.293 mm. The value of the SMD calculated using the correlation from the equation 3, at 6 bar gauge pressure was found to be 0.317 mm.

Data from water mist systems available in the market also employ similar droplet sizes as obtained from current opposed jet nozzle.

#### VII. Conclusion

A spray nozzle based on opposed jet configuration has been developed suitable for use in portable water based fire extinguishers.

The spray nozzle is studied for droplet size and distribution photographically. The spray is found have an SMD in the range of 0.3 mm to 0.4 mm which is considered appropriate for use in water extinguishment of Class A fires in literature. Spray SMD is also calculated from empirical correlations. Calculated values of SMD for the spray geometry also lie in the range of 0.3 to 0.4 mm. Study of expensive 'water mist' fire extinguishers commercially available indicates use of similar water particle sizes. Studies are being carried out to examine the effect of spray penetration to ensure the effectiveness of employed application density.

### References

- [1] G. Grant, J. Brenton, D. Drysdale' "Fire Supression by Water Sprays", progress in energy and combustion science 26 (2000) 79-130
- [2] Zhigang Liu and Andrew K. Kim "A Review of water mist fire suppression systems –fundamental studies", Journal of fire protection engineering, Vol. 10, No. 3, 2000, pp. 32-50.
- [3] KC Adiga and Heather D. Willauer, Ramagopal Ananth, and Frederick W. Williams "Droplet Breakup Energies and Formation of Ultra-Fine Mist", Journal of fire protection engineering,
- [4] Meenakshi Gupta, R. Rajora, "Effect of Air or Nitrogen on Fire Suppression Performance of Twin Fluid Water Mist System in an Enclosed Chamber", Proceedings of fire science and technology, FIRST Nov 3-4, 2011
- [5] KC Adiga, Robert F. Hatcher Jr, Ronald S. Sheinson, Frederick W. Williams, Scott ayers, "A Computational and Experimental Study of Ultra Fine Water Mist as a Total Flooding Agent", fire safety journal 42 (2007) 150-160.
- [6] SN Sridhara and BN Raghunandan, "Photographic Investigations of Jet Disintegration in Air-blast Sprays", Journal of applied fluid mechanics, vol 3, no. 2, pp 111-123, 2010
- [7] GV Roberts, "An Experimental Investigation of Thermal Absorption by Water Spray", Fire and emergency planning directorate fire research and development group.
- [8] Kurt a. Estes and Issam Mudawar "Correlation of Sauter Mean Diameter and Critical Heat Flux for Spray Cooling of Small Surfaces" vol,38, 16,pp. 2985-2996, 1995.
- [9] Viriato Semibo, Pedro Andrade and Maria da GraCa Carvalho, "Spray Characterization: Numerical Prediction of Sauter Mean Diameter and Droplet Size Distribution" fuel vol. 75, no. 15, pp, 1707-1714, 1996.