

Differential Relay Reliability Impliment Enhancement of Power Transformer

Raju (M. Tech), K. Ramamohan Reddy, M.Tech (P.hd)

Department of EEE, KSRM College of Engineering. Kadapa.

ABSTRACT: This paper presents an improvement of digital differential relay reliability for protecting a large power transfer is discussed. First, the Fourier sine and cosine coefficients required for fundamental, second third and fifth harmonics determination have been calculated using rectangular transfer technique. Then, these harmonics have been used in harmonics restrain and blocking techniques used in differential protection system. Simulation testes have been carried out on a variety of magnetizing conditions (normal aperiodic inrush and over excitation conditions) using Simulink? MATLAB.

Index-terms: Power transformer, Differential protection, Inrush current, Fourier coefficients, Rectangular transfer techniques.

I. INTRODUCTION

The main purpose of power systems is to generate, transmit, and distribute electric energy to customers without interruptions and in the most economical and safe manner. Power systems are divided into subsystems generation, transformation, transmission and distribution which are composed of costly components.

The role of protection ensures that, in the event of a fault, the faulted element must be disconnected from the system for isolating the fault to prevent further damage to the components of the system through which the fault currents were flowing. A power transformer is mostly protected against internal fault using a differential protection which is sensitive and a fast clearing technique. This technique of protection detects nonzero differential current, then activates a circuit breaker that disconnects the transformer. However, this nonzero differential current may be produced by transformer magnetization, due to so called inrush current of over-excitation, and may cause the protective system to operate unnecessarily. This magnetization current is a transient current that appears only when a transformer is first energized or after clearing external faults.

During periodic inrush condition due to over-excitation the third and fifth harmonic components are largely seen: however, during the normal aperiodic inrush conditions, the second harmonic is relatively high.

The transformer differential protection scheme has to be improved so that it can distinguish between nonzero differential current produced by magnetization current and that produced by internal fault. Several methods have been proposed to blind the differential protection system to magnetization current where the harmonic components have been used as means of detection. However, the digital computer based protection offers a number of advantages over the conventional ones. So, the security and reliability have been improved; it remains only to develop an efficient algorithm requiring less time consuming calculations.

The alternative approaches to the digital protection of power transformer have been proposed to date; one using a digital filtering approach and the other using sine and cosine wave correlation to yield the fundamental and higher harmonic components required for protection. This paper presents a new approach which the sine and cosine Fourier coefficients are expressed in terms of rectangular transfer coefficients that are obtained from the data samples by only additions and subtractions.

II. TRANSFORMER DIFFERENTIAL PROTECTION

The most important devices employed in the protection system are protective relays. These devices may be flexible, economic and provide reliable, fast and inexpensive protection. The IEEE standard defines a protective relay as "a relay whose function is to detect faults or other power conditions of an abnormal or dangerous nature and to initiate.

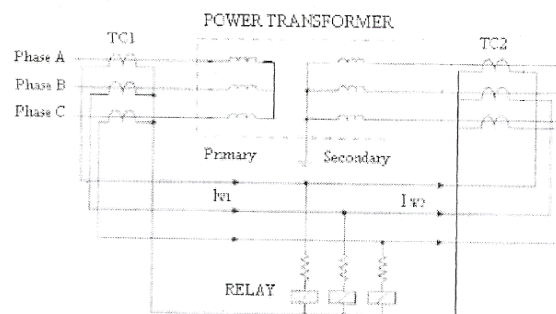

Fig.1 Typical Differential power transformer protection relay.

Appropriate control circuit action the differential protection principle is simple and provides the best protection for the phase and ground faults.

Differential relay is generally used for protection the power transformer against internal fault. Figure I shows a typical differential relay connection diagram.

Even differential protection is relatively simple to apply, but it has problems. One of the problem of the differential relay is its operation due to transformer magnetizing current which is well known, this current appears on only one input to the differential relay (from the side of energization), thus the relay sees this situation as an internal fault. Figure 2 illustrates the typical current waveform present during a one phase transformer bank energization.

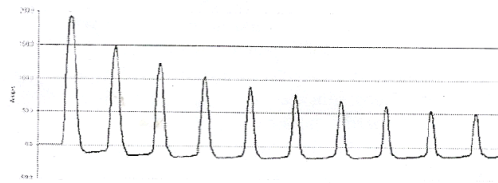

Fig.2 Transformer Inrush (one Phase)

An inrush current is the surge of transient current that appears in a transformer. The exciting voltage applied to the primary of the transformer forces the flux to build up to a maximum theoretical value of double the steady state flux plus remanence, therefore the transformer is greatly saturated and draws more current which can be in excess of the full load rating of the transformer windings.

This current is high magnitude, harmonic-rich currents generated when transformer cores are driven into saturation.

$$\phi_{MAX} = 2\phi_M + \phi_R \quad (1)$$

Although it is usually considered as a result of energizing a transformer, the magnetizing inrush may be also caused by.

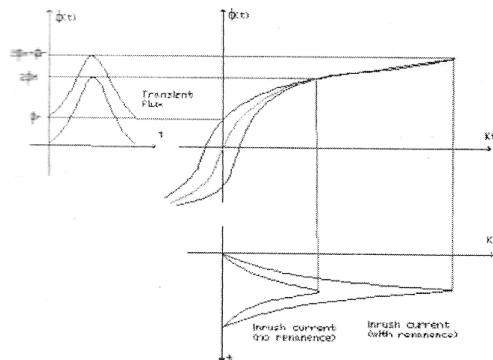

Fig.3 Typical curve of fluxes and inrush current.

1. Occurrence of an enternal fault,
2. Voltage recovery after clearing an external fulut,
3. Change of the type of a fault,
4. Energizing of a transformer in parallel with a transformer that is already in service.

The solpe, magnitude and duration of inrush current depend on several factors.

- Size of a transformer
- Impedance of the system from which a transformer is energized.
- Magnetic properties of the core material,
- Magnetic residual in the core,
- Why a transformer is switched on (inner, outer winding, type of switchgear)
- When a transformer is switched on.

A. Problems Caused by Inrush Current

An important feature of this inrush current is that the current is not pure fundamental frequency waveform. From a power quality point of view, the magnetizing inrush current can be considered as a distorted wave with two kinds of disturbances.

Harmonics: Part research has shown that magnetizing inrush produces currents with a high second harmonic content (8), with relatively low third harmonic content (9) and higher harmonics with different small values, so that can be neglected.

Unblance: Current unbalance cannot be considered a disturbance. Asymmetrical load produce unbalance currents. In the same way, the magnetizing inrush current produces current unbalance during magnetization, but is not a fault, and the differential relay must not trip.

Other disturbances caused by inrush may occur due to:

1. Incorrect operation and failures of electrical machines and relay systems.
2. Irregular voltage distribution long the transformer windings.
3. High amount of voltage drop at the power system at energization timers
4. Electrical and mechanical vibrations among the windings of the transformer.

B. Differential Protection Methods.

The most important means of protection based on the comparison of the transformer primary and secondary currents. When these currents deviate from a predefined relationship, an internal fault is considered and the transformer is de-energized. However, during transient primary magnetizing inrush conditions, the transformer can carry very high primary current and no secondary current.

1. Power differential method: this method is based on the idea that the average power drawn by a power transformer is almost zero on inrush, while during a fault the average power is significantly higher
2. Rectifier relay: this method is based on the fact that magnetizing inrush current is in effect a half-frequency wave. Relays based on this method use rectifiers and have one element functioning on positive current and one on negative current.
3. Waveform recognition: it is the method of measuring dwell-time” of the current waveform, that is, how long it stays close to zero, indicating a full dc-offset, which uses to declare an inrush condition. Such relays typically expect the dwell time to be at least ¼ of a cycle, and will restrain tripping if this is measured.
4. Flux-current: A new simple and efficient technique for inrush current reduction based on the calculated flux in the core. As its advantage, this approach tides together the cause of the problem (saturation of the core as a source of the current unbalance) with the phenomenon used for recognition.
5. Cross blocking: it is a “method that blocks all tripping if any relay detects inrush. Any of the relays that use single-phase inrush detection methods can utilize cross blocking.
6. Harmonic current restraint: This is the most common method and widely used for the detection of inrush current in power transformer.

C. Harmonic Current Restraint

Different schemes currently used to distinguish between magnetizing Inrush and fault current are based on:

1. Second harmonics restraint principle.
2. Voltage restraint principle.
3. Restraint principle based on currents and voltages of the transformers.

Simple 2nd harmonic restraint: This method has been used for many years and simple employs a percentage level of 2nd harmonic content (or THE in some relays) in the differential current. If the 2nd harmonic content present in the waveform is above a threshold (typical thresholds are between 15 and 35% of fundamental) the relay is restrained. This is simply a per-phase calculation of 2nd harmonic current (in Amps) divided by fundamental current (in Amps) .

Shared 2nd harmonic restraint: The same methods as described above with the exception that the numerator is the sum of the 2nd harmonic current from all three differential currents is 9A and the particular phase of interest (this calculation is performed for each phase) has 10A of fundamental its restraining quantity is 90%.

III. MAGNETIZING CURRENT ALGORITHM

In a large power transformer, any switching action can produce a large current peak due to the saturation of the transformer iron core. Owing to this core saturation, the inrush current contains, in addition to the harmonic components, a decaying dc current. Therefore, the inrush current can be modeled as follows:

$$i(t) = I_o \exp(-\lambda t) + \sum_{k=1}^n I_k \sin(k\omega_1 t + \theta_k) \quad (2)$$

Where k determines the order of harmonic, and ω_1 is the frequency of the fundamental component. The decaying dc current can be represented by a Taylor expansion of two terms:

$$I_o \exp(-\lambda t) \approx I_o - I_o \lambda t \quad (3)$$

If it is assumed that the inrush current does not contain more than five harmonics, Eq.(1) becomes.

$$i(t) = I_o - I_o \lambda t + \sum_{k=1}^5 I_k \cos \theta_k \sin(k\omega t) \quad (4)$$

$$S_5 = \left(1 + \frac{1}{16}\right) S_3'$$

$$C_5 = \left(1 - \frac{1}{16}\right) C_5'$$

The harmonics components are found to be

$$I_1 = \frac{2}{12} [S_1^2 + C_1^2]^2 \tag{13a}$$

$$I_2 = \frac{2}{12} [S_2^2 + C_2^2]^2 \tag{13b}$$

$$I_5 = \frac{2}{12} [S_5^2 + C_5^2]^2 \tag{13c}$$

After extraction of the fundamental, the second and the fifth harmonic components, these harmonic components will be used to produce restraining signal that may be used to block there relay. Otherwise, for internal fault case, the relay operates.

IV. PROTECTION SYSTEM IMPLEMENTATION

The Protection System approach has been implemented using Matlab/Simulink with the necessary tool box. The Matlab is powerful software program used for any test and simulation. The characteristics of the differential protection scheme that has been used are plotted in Where there are two straight lines give with a slope of K1=0.25 and a slope of K2=0.6 which range from Irt0 to Irt1 and from Irt1 to Irt2, respectively, and a horizontal, straight line defining the relay minimum pickup current, Iop0=0.3A. The relay operating is located above the slope, and the restraining region is below the slope.

A dual-slope percentage characteristic provides further security for external faults. It is represented as a dashed line in.

The dual-slope percentage pattern adds a restraint area and avoids mal-operation caused by saturation. In comparison with a single-slope percentage scheme, the dual-slop percentage current differential protection can be regarded as a better curve fitting of transformer operational principles.

A Systems Description And scopes

The Simulink model a illustrated in consists of a three-phase transformer rated 225 kVA, 2400 V/600V, 60Hz, connected to a 1 MVA, 2400 V power network. A 112.5kW resistive load (50% of transformer nominal power) is connected on the 600V side. Each phase of the transformer consists of two windings both connected in wye with a grounded neutral. In a system relaying block, the currents that have been measured on Buses B1 and B2 pass through a second order Butterworth low pass filter with a cut

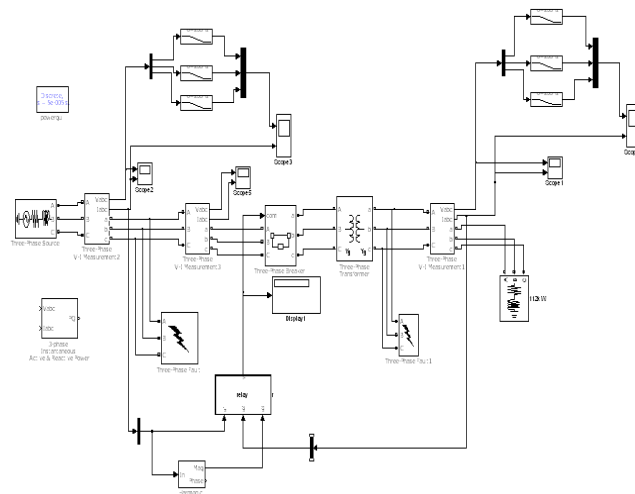
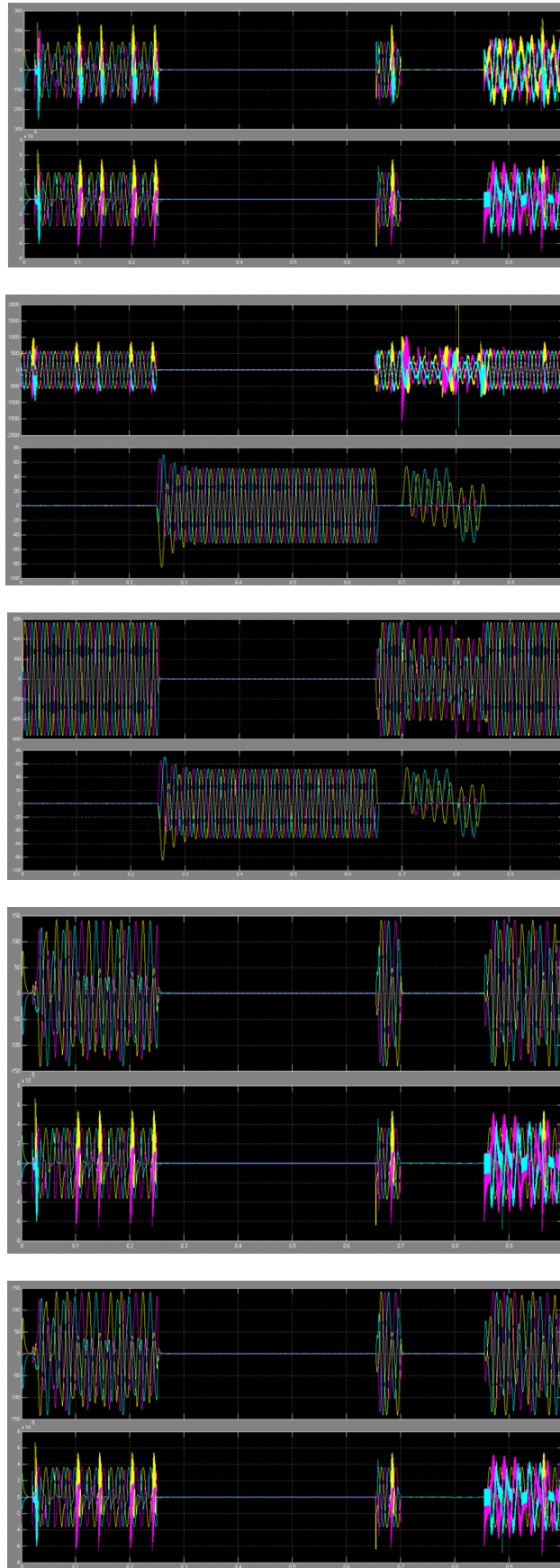

Fig.simulation block diagram



Outputs of simulation results

Off frequency of 600 Hz, which offers a maximum flat response in the pass band and a quite good attenuation slope. After that, the differential and restraint currents using blocks included in Simulink library and our algorithm, have been calculated. The generated signals are used in the relay operational principles.

V. SIMULATION RESULTS

The was simulated in MATLAB using the Simpower system toolbox of SIMULINK. The digital by simulation for magnetization currents and internal fault cases. These currents are generated when the circuit breaker is closed to connect the transformer and external fault appears as shown in Fig 6. the currents are measured by current transformers on buses B1 and B2 and then introduced to the relay. Some parameters have been made variable to allow performing all possible cases of test. Two test cases have been performed.

a) switching on the transformer and then applying an external fault as shown in Fig6

b) switching on the transformer and then applying an internal fault as shown in Fig7

figure 6 shows the plots of the differential currents then the transformer is switched on at $t=0.08$ sec and then an external fault at 0.25 sec and finally this fault cleared at 0.65 sec. In fig(7) the differential current as well the restrain current are shown for case (b) switching on the transformer at $t=0$ and then applying an internal fault at $t=0.6$ sec. However, fig.8 shows the plots of test case(b) for the relay trips. The output and response time of the relay are shown in this figure. However, the trip times that have been found. Include the waiting time of one cycle of the power frequency. This delay has been introduced to prevent false trip conditions. It is possible to reduce the time delay to achieve faster tripping. It can be noted that the relay exhibits a good response in all considered cases. This method allows obtaining a rapid and accurate response of the digital protection scheme. Moreover, it provides a good discrimination between the inrush current and internal fault current

VI. CONCLUSION

This paper, presents, an attempt has been made through the use of MATLAB/SIMULINK to test a new approach applied to digital differential protection relay for a large power transformer. First, the Fourier sine and cosine coefficients required for fundamental, second, third and fifth harmonics extraction have been calculated using rectangular transfer technique. Then, these harmonic components have been used in harmonics restraint and blocking techniques which may be utilized in differential protection system. Testes have been carried out on a variety of magnetizing conditions (normal aperiodic inrush and over excitation conditions due to external fault) as well as internal fault. It can be noted that, from the obtained simulation results using Simulink/MATLAB, the developed scheme provides good discrimination between the magnetizing current and the internal fault current.

REFERENCES

- 1) J.S thorp, A.G.Phadke, A Microprocessor Based three-Phase Transformer Differential Relay, IEEE Trans, PAS-101,P426,1982
- 2) M.A.Rahman, P.K.Dahs, "Fast Algorithm for Digital Protection of Power Transformer" IEEE proc., Vol 129-C2,P,79,1982.
- 3) M.A.Rahman, P.K.Dahs, "Fast Algorithm for Digital Protection of Power Transformer" IEEE proc., Vol 129-C2,P,79,1982.
- 4) B Kaszenny, and A.kulidjiant, "An Improved Transformer inrush restraint current Algorithm" 53rd Annual conference for protective relay engineering, College, April 11-13,2000.
- 5) F.Meclic, R.Girgis,Z. Gajic, Power Transformer Characteristics and their Effects on protective Relays" 33rd Western protective Relays conference, October 17-19, 2006.
- 6) R. Bouderbala, H.Bentarzi and O. Abderrahmane. "A New approach Applied to Digital Differential Protection for a Large Power Transformer" the 9th WSEAS international conference on Recent Researches in Circuits, Systems, Electronics, Control & Signal Processing Proceeding, PP.202-205, ISBN:978-960-474-262-2, Athena, Greece, Dec.29-31-2010.
- 7) A.Ouadi, H.Bentarzi, and J.C.Maun, "Improvement of phasor Measurement Unit Performance" the 9th WSEAS international control & signal processing proceeding, pp.202-205, ISBN: 978-960-474-262-2, Athena, Greece, Dec.29-31-2010