

## Need of Lapping Machine for Valve Component: A Case Study

S. M. Fulmali,<sup>1</sup> R.B.Chadge<sup>2</sup>

<sup>1</sup>Student of M.Tech, Yeshwantrao Chavan College of Engineering, Nagpur

<sup>2</sup>Asst. Professor, Yeshwantrao Chavan College of Engineering, Nagpur

**ABSTRACT:** Lapping process is characterized by its low speed, low pressure, and low material removal rate. This process is used in achieving finer surfaces and closer fits, correction of minor imperfections, and maintaining close tolerances. During the process of lapping, the mechanisms of surface formation and removal rate are decisively influenced by the movement type of the individual grains within the lapping abrasive. A gate valve is used to start and stop the flow of fluid. So the wedge and seat ring of a valve are in continuous pressure of fluid flow and due to opening and closing of valve these component get wear and they need lapping during reconditioning. This paper will share the need, requirement and application of lapping during the reconditioning of valve.

This paper will explore the current working condition of lapping machine in valve industry. It will elaborate the effect of abrasive particles, working speed, surface roughness and other related parameters. What are the difficulties they are facing during the valve reconditioning related to lapping, will be discussed. Current set up and the changes required in this model are suggested with the proposed model.

**Key words:** Lapping process, wedge, seat ring, abrasive particles.

### I. INTRODUCTION

Lapping is a micro finishing operation which is required to require getting a mirror like surface finish on the mating component. It provides a good strength to joint formed. Lapping has been used extensively in the manufacture of optical mirrors and lenses, ceramics, hard disk drive, semi-conductor wafers, valve seats, ball bearings, and, and many more parts[1]. Several factors need to be considered during the process of lapping. This includes factors such as type of machine, condition of the lap plate surface, speed of the lap plate, type of abrasive, type of carrier fluid, slurry concentration, slurry flow rate, size and shape of abrasive, material of the lap plate, rigidity of the lap plate, applied force on the work piece, time of operation and duration between the two consecutive instances of application of fresh abrasive slurry [1, 2].

### II. LITERATURE RELATED TO LAPPING

Commonly used as a finishing operation, lapping has been used for achieving ultra-high finishes and close tolerances between mating pieces. This process is characterized by its low speed, low pressure, and low material removal. The lapping process is carried out by applying loose abrasive grains between two surfaces and causing a relative motion between the two surfaces resulting in a finish of multi-directional lay[1].

Lalit Suhas Deshpande [1] stated the procedure and testing on valve component. They performed the test on two materials stainless steel (S31600), and bronze (C86300). These materials were identified as commonly used materials in the manufacturing of relief valve seats and thus selected for the experiments. The most commonly used abrasive materials for lapping of valves seats are alumina and silicon carbide. Metal tubes were machined in the form of circular rings resembling valve seats. The papers explain the result of testing with respect to varying speed, size of abrasive particles, material removal rate etc.

C. J. Evans [3] stated the selection of related component used in the lapping and polishing operation. The paper explains the role of granules in the slurry used for the removal of material during the lapping process. It also explains the material that should be used for the lap, its hardness and what should be the material removal rate in the process of lapping.

The physical scale of material removal processes in polishing is such that it is difficult (practically impossible) to observe them directly. Much of what we know about the fundamental mechanisms involved in the process has been derived either by correlating macroscopic measurements of process outputs with models, or by extrapolation from experiments at scales which can conveniently be observed.

J. Kang[4] in this paper Two types of HIPed Si3 N4 bearing ball blanks with different surface hardness and fracture toughness were lapped under various loads, speeds, and lubricants using a novel eccentric lapping machine. The lapped surfaces were examined by optical microscope and SEM. The experimental results show that the material removal rate for type 1 ball blanks were 3–4-fold of type 2 in most cases. Different lapping fluids affected the material removal rate at lower lapping loads, but they had much less influence on the material removal rate at higher lapping loads.

### III. NEED OF LAPPING FOR VALVE COMPONENT

Valve lapping is a essential part of maintenance work that often interrupt production work. Repairing leaking valve in industry is a laborious operation involving extended downtime, production losses and substantial unwanted cost. The given figure shows different parts of a gate valve.

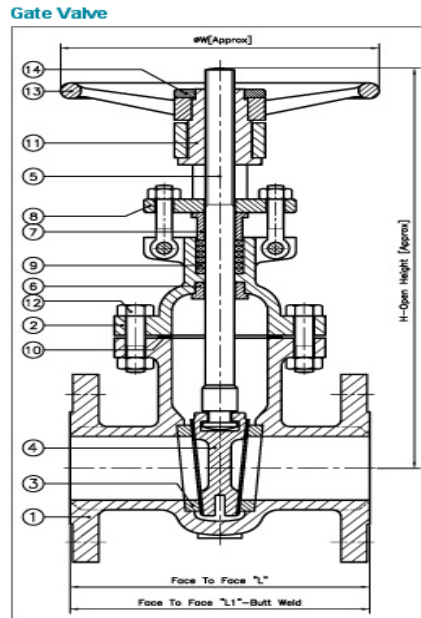

Fig.1. Gate Valve

**Parts description:-**

- 1.Body 2.Bonnet 3. Seat 4.Wedge 5. Stem 6. Bach seat bush 7. Gland bush 8. Gland Flange 9. Gland packing 10. Gasket 11. Yoke sleeve 12. Bonnet Bolt and Nut 13. Hand wheel 14. Hand wheel Nut.

There are various reasons why repairing valves has many advantages, since:

- repair costs are only 5 – 35% of the procurement price of replacement valves
- maintaining stocks of all replacement valves ties up too much capital
- the delivery times of replacement valves can be extremely long, which can cause serious (and therefore expensive) production problems.

So we are trying to develop a set up for lapping operation which will be a portable one, available at cheaper cost and will perform lapping with minimum set up time.

**IV. COMPONENT THAT REQUIRE LAPPING**

**4.1. Wedge of a valve:**

This is a wedge of a valve which is under continuous pressure of fluid flow. The sizes of the wedge varies as per the size of valve for example 2”,4”,6” etc. valves . To close the valve these wedge are mesh with the seat ring. These wedge requires lapping after 60-70 openings of valve. To get a leak proof component these portion requires lapping.



Fig. 1.Wedge of valve



Fig. 2.Wedge

**4.2. Seat Ring**

Wedge or disc meshes with the seat ring of valve. It is actually a ring made up of stainless steel , bronze etc. material. The shape of seat ring goes on changing with continuous use. It becomes tapered and get leaked so it requires lapping. Size of seat ring also varies as per the size of valve. Small size seat rings are either press fitted or they may be welded to sustain fluid pressure.



**Fig.3. Seat ring**

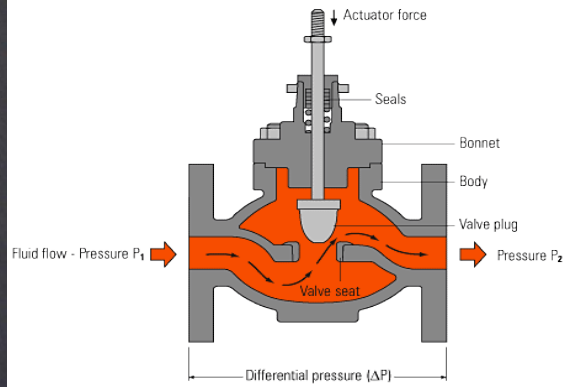

**Fig.4. flow through valve**

### V. DEVELOPMENT OF LAPPING MACHINE

A visit to an industry it is being observed that they were performing lapping operation on a set up which was developed by them. They fixed the lapping tool to the conventional lapping machine which is fixed. They fixed the valve on a vice and perform lapping on the valves.

Observing the operation we are trying to propose on model which will be portable, can be handled by one person and it will reduce the set up time also.

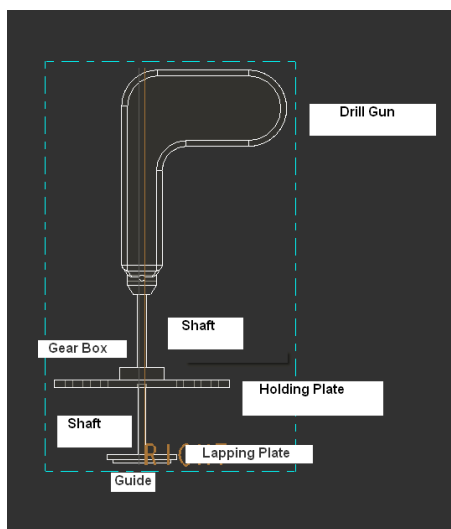

**Fig.5. Set up used in industry**

### VI. PROPOSED MODEL OF LAPPING MACHINE

A high torque drilling machine is used which will be generating a shaft speed of around 240 rpm. Through this shaft rpm is transferred to reduction gear box which will reduce it to 80-100 rpm. This speed is best for performing low speed lapping operation [1,3]. This gear box is mounted on holding plate which has holes on it. This plate will help us to hold the set up on frame for lapping wedge or hold the set up on body of valve.

Shaft through that gear box is connected with the lapping plate which is made up of cast iron [3]. A guide is provided at the centre to keep lap steady. The distance between seat ring and body of valve will vary according to the size of valve. So length of shaft will be according to the size of valve.



**Fig.6. Drawing of proposed model**

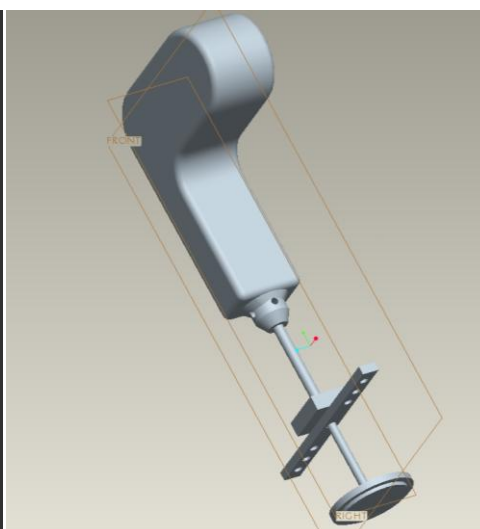

**Fig.7. CAD model for lapping machine**

## VII. ABRASIVE MATERIAL USED FOR LAPPING

The most commonly used abrasive materials for lapping of valves seats are alumina and silicon carbide. It is the objective of this research to obtain sufficient data by lapping. Three types of abrasives: (1) garnet, (2) alun-dum (aluminum oxide), and (3) crastolon (silicon carbide) (4) CARBURANDM (silicon carbide) were used to lap the work pieces. Generally, the high peaks are abraded by coarse grains of average diameter about 80 mm (F80: coarse lapping), the average height s peak s by grain size between 40 and 20 mm (F40 and F20: average lapping ) and the low height s peaks by fine grain size of 7 mm (F7: fine lapping ) are available for lapping. We will perform coarse lapping and fine lapping on valve component.

The material removal rate is calculated by measuring the change in the height of the specimens before and after lapping with selected abrasives and dividing the height difference by the amount of time the process of lapping was performed (20 min period). Xiaobin and Peterson [1, 7] relationship was used for the calculation of MRR as:

$$MRR=dH/dt=\Delta H/\Delta t=(H1 - H2)/t$$

Where dH is the change in thickness, dt is the change in time, H1 is the average height of the specimen before lapping, H2 is the average height of the specimen after lapping and t is the time of lapping (a 20 min period).

## VIII. CONCLUSION

The above research work and the proposed model can provide benefit in the lapping of valve component. Model will provide portability and reduce the set up time for lapping to some extent. The paper shows the importance of lapping operation in a valve industry. It show the size and type of abrasive used for valve lapping. As compared to the available machine for lapping, this proposed model will be the cheaper model. It will prove to be an economical model. The number of labors require to operate this machine is only one and less skilled labor can operate this model.

## REFERENCES

- [1] Lalit Suhas Deshpande, Shivakumar Raman ,Owat Sunanta, Casmir Agbaraji “Observations in the flat lapping of stainless steel and bronze” Tribology International 40 (2007) 498 – 502,2007.
- [2] U. Heisel (I), J. Avroutine Institut fur Werkzeugmaschinen, “Process Analysis for the Evaluation of the Surface Formation and Removal Rate in Lapping” Wear 265 (2008) 105–116,2006.
- [3] C. J. Evans “Material Removal Mechanisms in Lapping and Polishing” peer reviewed 01-01-2003
- [4] J. Kang, M. Hadfield “Examination of the material removal mechanisms during the lapping process of advanced ceramic rolling elements”. Wear 258 (2005) 2–12.
- [5] N. Belkhir D. Bouzid V. Herold “Correlation between the surface quality and the abrasive grains wear in optical glass lapping” Tribology International 40 (2007) 498 – 502
- [6] J.K.Wang,Desi Somogoi“Flow Loop Testing and Validation of Thermal Binding Model for Wedge Gate Valve”.kalsi engineering
- [7] L. Xiaobin, M.L. Peterson, Material removal rate in flat lapping, J. Manuf.Process. 1 (1999) 71–78.